

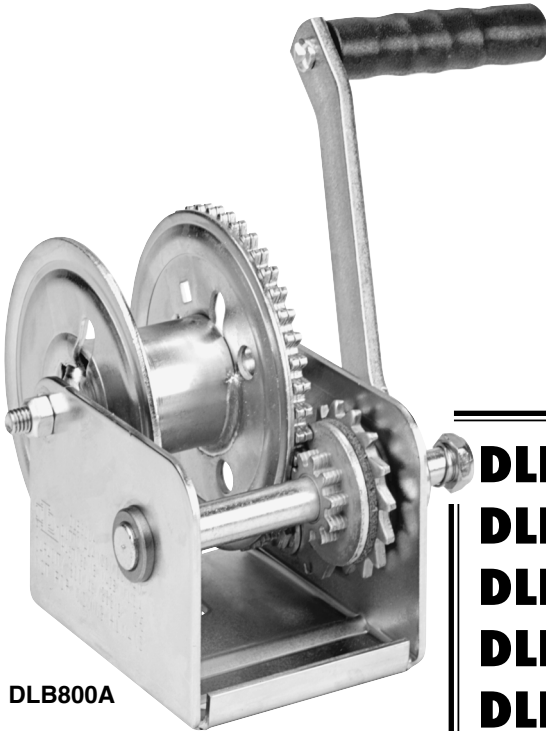

BRAKE WINCHES



DLB800A

DLB350A
DLB350AG
DLB800A
DLB800AG
DLB 1200A
DLB 1200AG
DLB 1500A
DLB 1500AG
DLB2000AG
DLB2500A

MANUFACTURED BY

MADE IN U.S.A.



DUTTON-LAINSON
COMPANY *SINCE 1886*

451 West 2nd St. • Hastings, NE 68902-0729 • TEL: 402-462-4141 • FAX: 402-460-4612
Web Site www.dutton-lainson.com

Dwg. No. 206306R 2/12

ISO 9001: 2008 REGISTERED Q.M.S.

⚠ WARNING READ INSTRUCTIONS CAREFULLY BEFORE ATTEMPTING TO INSTALL, OPERATE OR SERVICE THIS WINCH. FAILURE TO COMPLY WITH INSTRUCTIONS COULD RESULT IN SERIOUS OR FATAL INJURY. RETAIN THESE INSTRUCTIONS FOR FUTURE REFERENCE.



IMPORTANT SAFETY INFORMATION

- This brake winch is built for multi-purpose hauling and lifting operations. It is not to be used as a hoist for lifting, supporting or transporting people, or for loads over areas where people could be present.
- Respect this winch. High forces are created when using a winch, creating potential safety hazards. It should be operated and maintained in accordance with instructions. Never allow children or anyone who is not familiar with the operation of the winch to use it. A winch accident could result in personal injury.
- Check winch for proper operation on each use. Do not use if damaged. Seek immediate repairs.
- Never exceed rated capacity. Excess load may cause premature failure and could result in serious personal injury. This winch is rated on first layer of cable on the hub. Using more layers of cable increases the load on the winch.
- Never apply load on winch with cable fully extended. Keep at least three full turns of cable on the reel. Check cable on every use. Replace at the first sign of kinks, broken wires, deformation or any other damage.
- Secure load properly. When winching operation is complete, do not depend on winch to support load.
- Operate with hand power only. This winch should not be operated with a motor of any kind. If the winch cannot be cranked easily with one hand, it is probably over-loaded.
- If winch will be used in freezing, icy conditions, apply silicone spray to ratchet pawl and spacer items, V, W, X, or Y. Do not spray other brake mechanism parts.

ASSEMBLY – Thread the handle onto the winch drive shaft and be certain that a clicking noise is produced when the handle is turned clockwise. Install the spring and locknut (Items E and G) on the end of the drive shaft as shown on parts drawing. These parts may appear to serve no function, but they provide several important fail-safe features, and should not be altered or removed.

WINCH MOUNTING AND CABLE

ATTACHMENT – For maximum strength and safety, this winch should be mounted with three 3/8" bolts (M10), washers and lock washers. Use Grade 8 for 1500 lb/680 kg or greater capacity. (See parts drawing). Using fewer bolts or alternate locations will result in damage to the winch base and the winch may malfunction.

Attach cable or rope by method shown in sketch.

OPERATING INSTRUCTIONS – Wind cable on winch reel by turning winch handle in clockwise direction. This should produce a loud, sharp, clicking noise. The load will remain in position when the handle is released. Wind cable off the winch reel by turning winch handle counterclockwise (no noise will be produced). The load will remain in position when the handle is released, but for extra security it is recommended that the handle be turned clockwise until at least two clicks are heard. This will add extra tightness to the brake mechanism. Always satisfy yourself that the winch is holding the load before releasing the winch handle.

⚠ IMPORTANT: Sufficient load must be applied to the cable to overcome internal resistance and operate the brake properly, otherwise turning the crank handle counterclockwise will only remove the han-

dle from the shaft – the reel will not turn. The minimum operating load requirement is 50 lb (23 kg) for Models DLB350A, DLB350AG, DLB800A, DLB800AG, DLB1200A and DLB1200AG, 75 lb (34 kg) for DLB1500A and DLB1500AG, 175 lb (80 kg) for DLB2000AG and DLB2500A.

Models DLB805A, DLB1205A, & DLB1505A, are equipped with a lockout lever for the purpose of 'freewheeling' cable out when there is no load on the winch. To 'freewheel' cable out, simply turn the handle counterclockwise until lockout lever can be engaged behind handle hub. In this condition cable can be easily pulled from the winch drum.

⚠ WARNING: Never put winch in freewheel mode if any potential for a load on the cable exists. Engaging the lockout lever keeps the winch from stopping in the event that a load is accidentally applied.

WINCH MAINTENANCE – In order to insure maximum performance, a periodic inspection for any necessary preventive maintenance should be made. Check at least once annually and more frequently when the winch is exposed to an environment which is particularly dirty or wet. For continued smooth performance and increased life, occasionally grease gears, reel shaft and handle threads. An

occasional drop of oil on the drive shaft bearings is also recommended. If winch will be used in freezing, icy conditions, apply silicone spray to ratchet pawl and spacer items V, W, X or Y. **Note:** Do not oil or grease brake mechanism items H and J.

Keep winch in good working order. Damaged or severely-worn parts create unnecessary dangers and could result in personal injury or property damage.

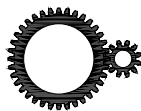
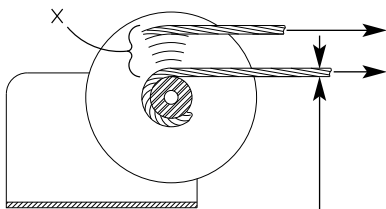

DLB350A DLB350AG	3.2:1
DLB800A DLB800AG	4.4:1
DLB1200A DLB1200AG	5.4:1
DLB1500A DLB1500AG	5.4:1
DLB2000AG DLB2500A	17.3:1

		X	
DLB350A, DLB350AG	10	110 lb/50kg	
	1	350 lb/160kg	
DLB800A, DLB800AG	9	330 lb/150kg	
	1	800 lb/360kg	
DLB1200A, DLB1200AG	8	551 lb/250kg	
	1	1200 lb/545kg	
DLB1500A, DLB1500AG	6	728 lb/330kg	
	1	1500 lb/680kg	
DLB2000AG	5	959 lb/435kg	
	1	2000 lb/905kg	
DLB2500A	5	1308 lb/593kg	
	1	2500 lb/1134kg	

DLB350A	1/8" (2000 lb) x 84'
DLB350AG	3mm (480kg) x 24.9m
DLB800A	3/16" (4200 lb) x 68'
DLB800AG	4mm (1080kg) x 23.0m
DLB1200A	7/32" (5600 lb) x 69'
DLB1200AG	5mm (1640kg) x 19.7m
DLB1500A	1/4" (7000 lb) x 60'
DLB1500AG	6mm (2040kg) x 15.1m
DLB2000AG	7mm (2720kg) x 8.9m
DLB2500A	5/16" (9800 lb) x 34'

ENGLISH – DECLARATION OF CONFORMITY - Dutton-Lainson Company, Hastings, NE 68902-0729 U.S.A. manufactures and declares that the winch identified above fulfills all relevant provisions of the Directive 2006/42/EC. 'G' models also conform to harmonized standards EN 13157 and EN ISO 12100-1 & -2. The technical file may be obtained from the persons listed below.

DEUTSCH – KONFORMITÄTSEKTLÄRUNG - Dutton-Lainson Company, Hastings, NE 68902-0729, USA, der Hersteller der Winde, erklärt, dass die oben angegebene Winde alle relevanten Bestimmungen der Richtlinie 2006/42/EG erfüllt. Die 'G'-Modelle entsprechen außerdem den harmonisierten Normen EN 13157 und EN ISO 12100-1 und -2. Die technischen Unterlagen sind bei den nachfolgend aufgeführten Personen erhältlich.

ITALIANO – DICHIARAZIONE DI CONFORMITÀ - Il fabbricante, Dutton-Lainson Company, Hastings, NE 68902-0729 USA, dichiara che il verricello di cui sopra è conforme alle disposizioni della direttiva 2006/42/CE e che i modelli 'G' sono inoltre conformi alle norme armonizzate EN 13157 e EN ISO 12100-1 e -2. Il fascicolo tecnico può essere richiesto agli individui indicati qui di seguito.

NORSK – SAMSVARERKLÆRING - Dutton-Lainson Company, Hastings, NE 68902-0729 U.S.A. produserer og erklærer at vinsjen angitt ovenfor oppfyller alle relevante krav i direktivet 2006/42/EC. 'G'-modellene samsvarer også med de harmoniserte standardene EN 13157 og EN ISO 12100-1 og -2. Den tekniske filen kan skaffes fra personene som er opplistet nedenfor.

PORTUGUÊS – DECLARAÇÃO DE CONFORMIDADE - A empresa Dutton-Lainson Company, Hastings, NE 68902-0729, nos E.U.A., fabrica o guincho acima identificado e declara que este cumpre todas as provisões relevantes da Directiva 2006/42/CE. Os modelos 'G' cumprem também as normas harmonizadas EN 13157 e EN ISO 12100-1 e -2. Poderá obter o processo técnico junto das pessoas indicadas abaixo.

ESPAÑOL – DECLARACION DE HOMOLOGACION - Dutton-Lainson Company, de Hastings, NE 68902-0729 EE.UU., fabrica y declara que el cabrestante arriba identificado satisface todas las provisiones pertinentes de la directriz 2006/42/EC. Los modelos 'G' también satisfacen las normas armonizadas EN 13157 y EN ISO 12100-1 y -2. El archivo técnico puede obtenerse de las personas mencionadas a continuación.

SVENSKA – FÖRSÄKRAN OM ÖVERENSSTÄMMELSE - Dutton-Lainson Company, Hastings, Nebraska 68902-0729 U.S.A. tillverkar och försäkrar att denna vinsch överensstämmer med alla tillämpliga bestämmelser i Direktiv 2006/42/EC. 'G'-modeller är också förenliga med samordnade normer EN 13157 och EN ISO 12100-1 & -2. Den tekniska filen kan erhållas från de personer, som upptas nedan.

ΕΛΛΗΝΙΚΑ – ΔΗΛΩΣΗ ΣΥΜΜΟΡΦΩΣΗΣ - Η Dutton-Lainson Company, Hastings, NE 68902-0729 U.S.A. κατασκευάζει και δηλώνει ότι το βραδύλοκο που καθορίζεται παραπάνω πληροί όλες τις σχετικές διατάξεις της Οδηγίας 2006/42/ΕΚ. Τα μοντέλα 'G' επίσης συμμορφώνονται με τα εναρμονισμένα πρότυπα EN 13157 και EN ISO 12100-1 & -2. Ο τεχνικός φάκελος είναι διαθέσιμος από τα άτομα τα οποία αναγράφονται παρακάτω.

DANSK – ÖVERENSSTÄMMELSEERKLÄRING - Dutton-Lainson Company, Hastings, NE 68902-0729 USA fremstiller og erklærer, at skraldespillet identificeret ovenfor er i overensstemmelse med alle relevante krav i direktiv 2006/42/EU. 'G' modeller er ligeledes i overensstemmelse med de harmoniserede standarder EN 13157 og EN ISO 12100-1 og -2. Den tekniske fil kan rekvireres gennem de nedennævnte personer.

SUOMI – VAATIMUSTENMUKAISUUSVAKUUTUS - Dutton-Lainson Company, osoite Hastings, NE 68902-0729 U.S.A. vakuuttaa tämän vintturin valmistajana, että tämä vintturi noudattaa direktiivin 2006/42/EY olennaisia määräyksiä. 'G'-mallit ovat myös harmonisoitujen standardien EN 13157:n ja EN ISO 12100-1 ja EN ISO 12100-2:n mukaisia. Tekniset tiedot on saatavissa alla ilmoitetuilta henkilöiltä.

NEREDLANDS – VERKLARING VAN ÖVEREENSTEMMING - Dutton-Lainson Company, Hastings, NE 68902-0729 VS, fabrikant, verklaart dat de bovengenoemde lier voldoet aan alle betreffende bepalingen van richtlijn 2006/42/EC. 'G' modellen voldoen ook aan de geharmoniseerde normen EN 13157 en EN ISO 12100-1 en -2. Het technische bestand kan bij de hierna vermelde personen worden aangevraagd.

FRANÇAIS – DECLARATION DE CONFORMITÉ - Dutton-Lainson Company, Hastings, NE 68902-0729 U.S.A. construit le treuil mentionné ci-dessus et déclare qu'il répond à toutes les dispositions applicables de la Directive 2006/42/CE. Les modèles 'G' sont également conformes aux normes harmonisées EN 13157 et EN ISO 12100-1 et -2. Le dossier technique peut être obtenu auprès des personnes indiquées ci-dessous.

Hastings, NE USA
June 1, 2011

Ron Hease

Senior Vice President
Dutton-Lainson Company

Peter Munday
Bainbridge International Limited
8 Flanders Park, Hedge End, Southampton,
Hampshire, SO30 2FZ UK



DLB350A & DLB350AG Winch

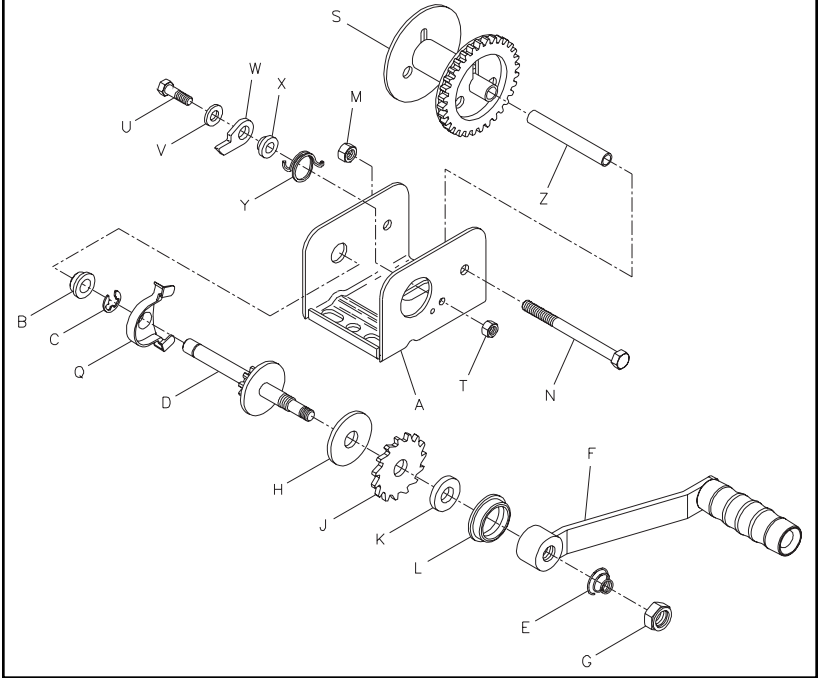

DLB800A & DLB800AG Winch

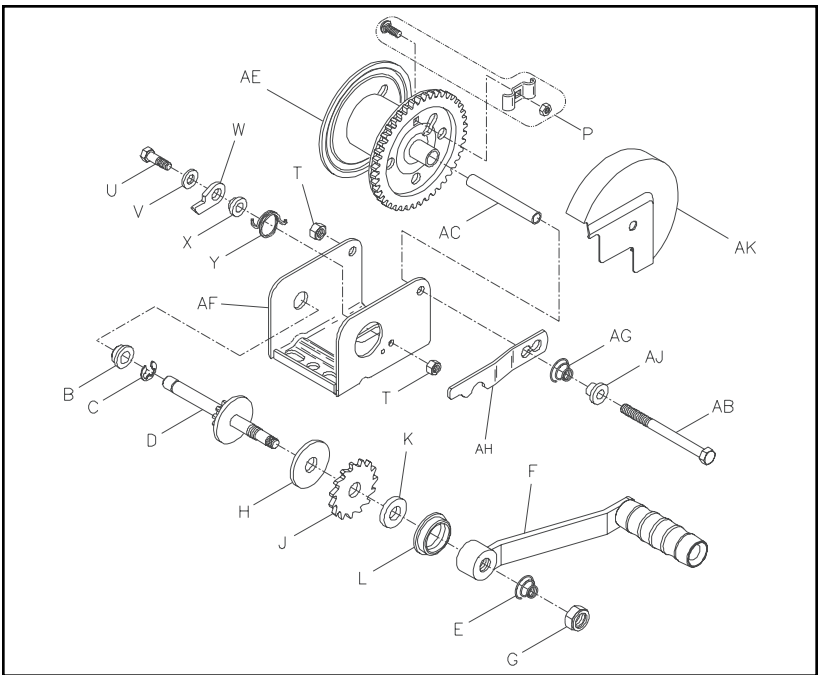



DLB1200A & DLB1200AG Winch

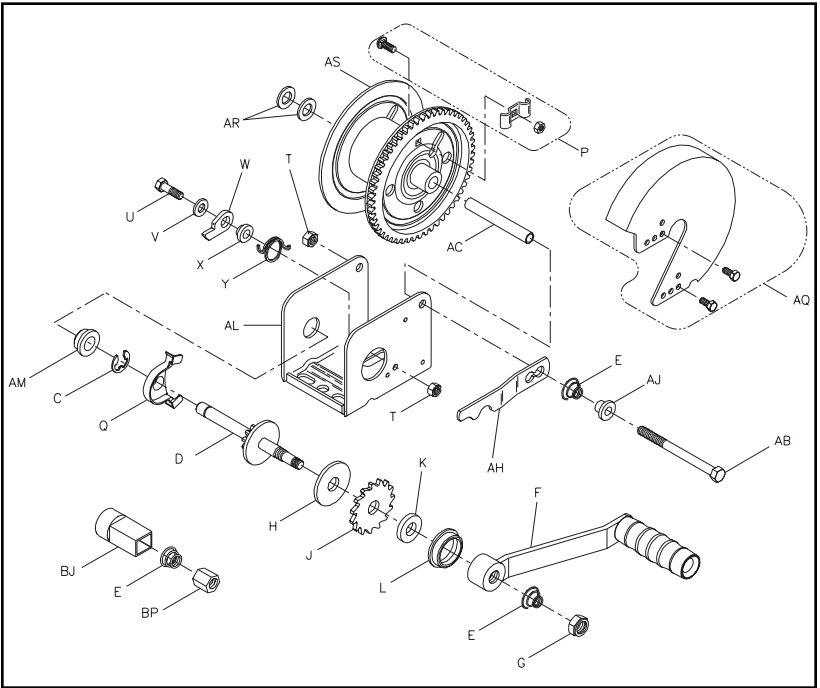

DLB1500A & DLB1500AG Winch

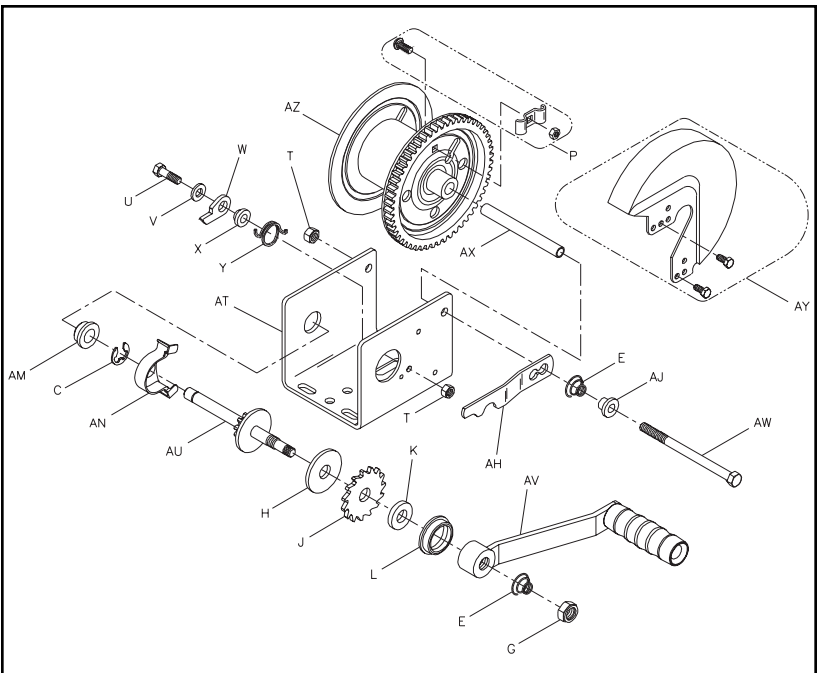

PARTS LIST

Ref	Description	Part No.
A	Base	404900*
A	Base – DLB 350AG	404945*
B	Bushing	204012
C	“E” Ring	205116
D	Drive Shaft	306061
E	Spring	204364
F	Handle – 7”	5703061
	Handle – 9-3/8”	5703103
G	Nut	205033
H	Pressure Plate	204362
H	Pressure Plate “G” Series	206620
J	Ratchet Wheel	404164
K	Pressure Washer	404163
L	Bushing	206328
M	Nut	205316
N	Bolt	205332
P	Rope Clamp Kit	5243506
Q	Gear Cover – “G” Series	406114
S	Reel	306075*
	Reel - DLB350AG	306167
T	Locknut	204803
U	Bolt	205167
V	Flat Washer	205055
W	Pawl	404409
	Pawl – “G” Series	404190
X	Spacer	404166
	Spacer – “G” Series	404191
Y	Spring	204363
	Spring – “G” Series	204460
Z	Reel Spacer	207183
AB	Bolt	203161
AC	Reel Spacer	204807
AE	Reel	306062*
AF	Base	404893*
	Base – DLB 800AG	404895*

Ref	Description	Part No.
AH	Lockout Lever (optional)	404579
AJ	Spacer (optional)	404166
AK	Gear Cover (optional)	
	Painted Bronze	5240346
	Plated	5240361
AL	Base	404896*
	Base – DLB 1200AG	404897*
AM	Bushing	204009
AN	Gear Cover – “G” Series	406115
AQ	Gear Cover (optional)	
	Painted Bronze	5240122
	Plated	5240221
AR	Spacer Washer	204360
AS	Reel	304754*
AS	Reel – 1-7/8” (optional)	304768*
AT	Base	404891*
	Base – DLB 1500AG	404892*
AU	Drive Shaft	304760
AV	Handle – 9-3/8”	5703103
	Handle – 12”	5703111
AW	Bolt	204804
AX	Reel Spacer	204808
AY	Gear Cover (optional)	
	Painted Bronze	5240387
	Plated	5240403
AZ	Reel	304755*
BA	Base – DLB2500A	406047*
	Base – DLB 2000AG	404899*
BB	Spacer	404434
BC	Bolt	205006
BD	Flat Washer	205139
BE	Intermed. Drive Shaft	306035
BF	Nut	205014
BH	Reel	304756*
BJ	Drive Hub (Optional)	304562
BM	Handle w/Lock Pin (Opt)	5703426
BN	Handle Hub (Optional)	304630
BP	Special Nut (Optional)	404970
BQ	“E” Ring	206162
BR	Bushing	206163
BS	Bolt	205335

To order replacement parts contact:

Dutton-Lainson Company

www.dlco.com

Tel: 800-569-6577

Fax: 402-460-4612

e-mail: DLsales@dutton-lainson.com

In Europe Contact

Bainbridge International Ltd.

8 Flanders Park

Hedge End

Southampton

Hampshire, SO30 2FZ UK

Tel: +44 (0) 1489-776050

Fax: +44 (0) 1489-776055

www.bainbridgmarine.co.uk

*Specify Color When Ordering



DLB2000AG & DLB2500A Winch

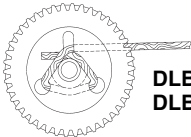
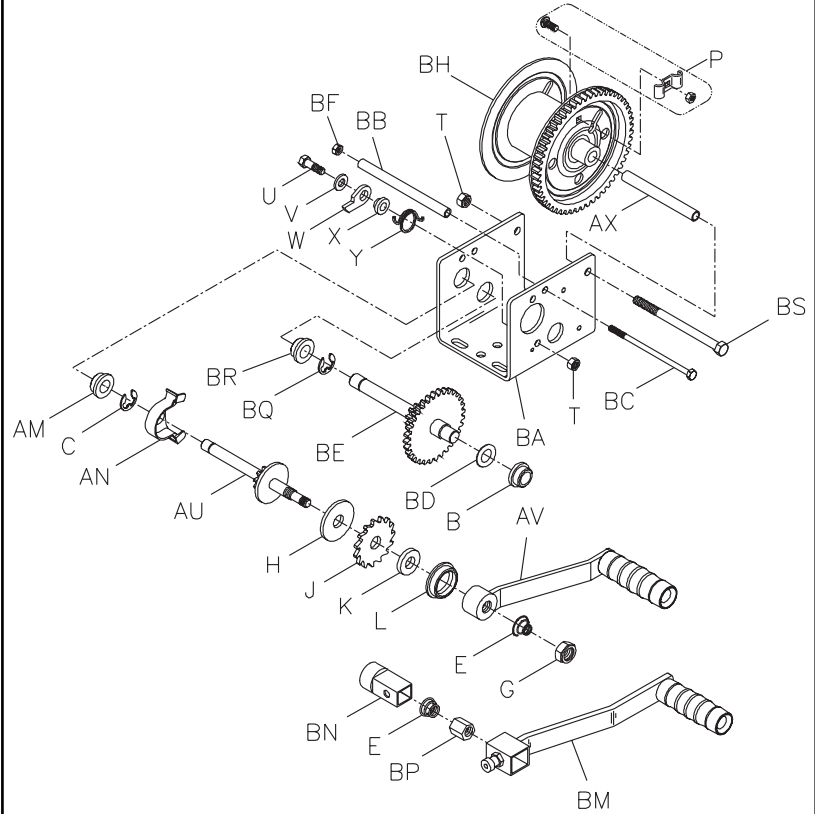

**DLB350A
DLB350AG**

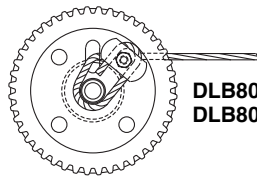

**DLB800A
DLB800AG**

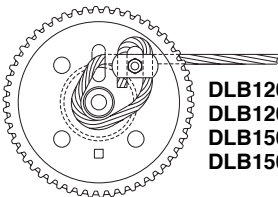

**DLB1200A
DLB1200AG
DLB1500A
DLB1500AG**

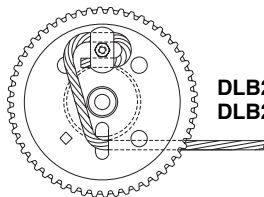

**DLB2500A
DLB2000AG**

Printed by:



**CORNHUSKER
PRESS** SINCE 1935

Hastings, NE • Grand Island, NE • Kearney, NE

©2011

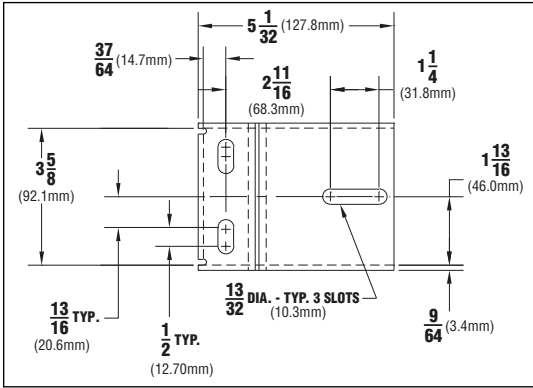

DLB350A, DLB350AG,
DLB800A, DLB800AG,
DLB1200A, DLB1200AG

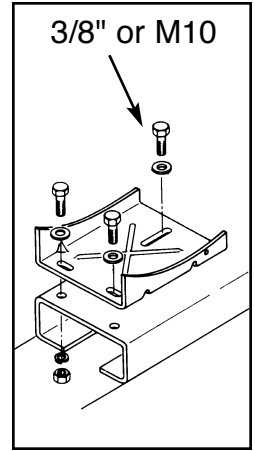

DLB1500A
DLB1500AG

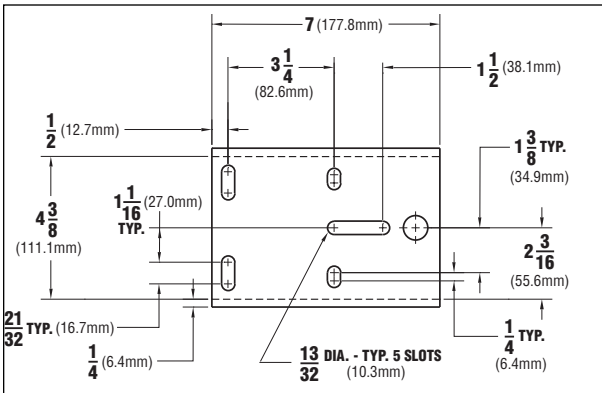
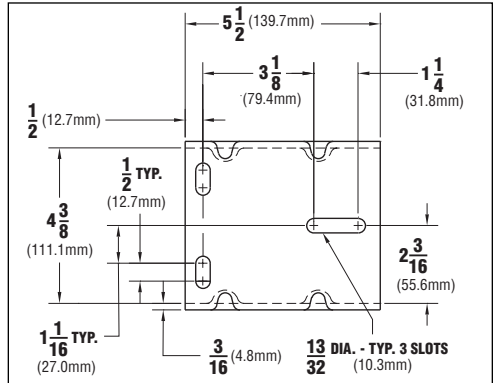

DLB2000AG
DLB2500A

-  **WARNING** Component parts should not be interchanged with the component parts of any other Dutton-Lainson model or other manufacturer's winches.
-  **ACHTUNG:** Die Komponenten dürfen nicht gegen andere Komponenten anderer Modelle der Dutton-Lainson Company oder der Winden anderer Hersteller ausgetauscht werden.
-  **ATTENZIONE:** Questi componenti non devono essere utilizzati in modo intercambiabile con i componenti di qualsiasi altro modello della Dutton-Lainson Company o con i verricelli di un altro fabbricante.
-  **ADVARSEL:** Disse komponentdelene skal ikke byttes om med komponentdeler for noen annen vinsj-verken fra Dutton-Lainson Company eller noen annen produsent.
-  **ADVERTENCIA:** No se debe intercambiar estas piezas con las de algún otro modelo de cabrestante de la Dutton-Lainson Company o de otro fabricante.
-  **VARNING:** Byt inte ut komponentdelarna mot komponentdelar från andra vinschar tillverkade av Dutton-Lainson Company eller från andra tillverkares vinschar (eller tvärtom).
-  **ΠΡΟΕΙΔΟΠΟΙΗΣΗ** Αυτά τα συνθετικά μέρη να μην αντικατασταθούν με συνθετικά μέρη άλλου μοντέλου της εταιρίας Δυττον-Λαινσον ή βαρούλκα άλλου εργοστασίου.
-  **ADVARSEL:** Disse komponentdele må ikke blive udskiftet med komponentdele, der hører til andre modeller fra Dutton-Lainson Company eller til spil af andre fabrikater.
-  **VAROITUS:** Tämän mallin ja muiden Dutton-Lainson Companyn tai muiden valmistajien vintturien osia ei saa vaihtaa keskenään.
-  **WAARSCHUWING:** Deze onderdelen mogen niet verwisseld worden met de onderdelen van andere liermodellen van Dutton-Lainson Company of van lieren van andere fabrikanten.
-  **MISE EN GARDE:** Ces composants ne doivent pas être utilisés de manière interchangeable avec les composants d'aucun autre modèle de Dutton-Lainson Company ou avec les treuils d'un autre fabricant.
-  **ADVERTÊNCIA:** Esses componentes não devem ser intercambiados com componentes de nenhum outro modelo da Dutton-Lainson Company nem de guinchos de outros fabricantes.

ENGLISH-To obtain a copy of the warranty in English, send a self-addressed envelope to: Dutton-Lainson Company; P.O. Box 729; Hastings NE 68902-0729; U.S.A.

DEUTSCH-Wenn Sie eine deutsche Kopie der Garantibestimmungen erhalten möchten, senden Sie bitte einen adressierten Rückumschlag an: Dutton-Lainson Company; P.O.Box 729; Hastings NE 68902-0729; USA

ITALIANO-Per ricevere una copia della garanzia in italiano, inviare una busta riportante il proprio indirizzo a: Dutton-Lainson Company, P.O. Box 729, Hastings NE 68902-0729 USA.

NORSK-En kopi av denne garantien på norsk fås ved å sende en konvolutt med eget navn og adresse, til Dutton-Lainson Company, P.O. Box 729, Hastings NE 68902-0729, USA

PORTUGUÊS-Para obter uma cópia da garantia em português, envie um envelope com a sua morada para: Dutton-Lainson; P. O. Box 729; Hastings NE 68902-0729; E.U.A.

ESPAÑOL-Para obtener una copia de la garantía en español, envíe un sobre con su dirección impresa a: Dutton-Lainson Company, P.O. Box 729; Hastings NE 68902-0729 EE.UU.

SVENSKA-För att erhålla ett exemplar av garantin på svenska skicka ett adresserat kuvert till: Dutton-Lainson Company, P.O.Box 729, Hastings NE 68902-0729 U.S.A.

ΕΛΛΗΝΙΚΑ-Για να λάβετε ένα αντίγραφο της εγγύησης στα Ελληνικά, στείλτε ένα φάκελο εσωκλείοντας τα ταχυδρομικά τέλη αποστολής στην εξής διεύθυνση: Dutton-Lainson Company, P.O.Box 729, Hastings NE 68902-0729 U.S.A..

DANSK-Man kan få garantibeviset på dansk ved at sende en svarkuvert til: Dutton-Lainson Company, P.O. Box 729, Hastings NE 68902-0729, USA.

SUOMI-Takuutodistuksesta saa suomenkielisen kopion lähettämällä riittävästi postimaksulla ja vastaanottajan osoitteella varustetun kirjekuoren osoitteeseen Dutton-Lainson Company, P.O. Box 729, Hastings NE 68902-0729, USA.

NEDERLANDS-Voor een exemplaar van de garantie in het Nederlands dient u een aan u zelf geadresseerde enveloppe te zenden naar: Dutton-Lainson Company; P.O. Box 729; Hastings NE 68902-0729; U.S.A.

FRANÇAIS-Pour obtenir une copie de la garantie en français, envoyer une enveloppe à votre nom et adresse à : Dutton-Lainson Company; P.O. Box 729; Hastings NE 68902-0729; U.S.A.